

DECLARATION OF PERFORMANCE

No. 0764-CPR-0388 – DK – English – vs02

1. *Unique identification code of the product type:*

Rockpanel A2, 8 mm finish Colours, Rockpanel A2, 8 mm finish Ply and Rockpanel A2, 8 mm finish ProtectPlus.

2. *Type, batch or serial number or any other element allowing identification of the construction product as required pursuant to Article 11 (4):*

Backside print on the board.

3. *Intended use / es*

Internal and external wall and ceiling finishes.

4. *Manufacturer*

ROCKWOOL B.V.
Industrieweg 15
NL-6045 JG Roermond, Netherlands
Tel.: +31 475 353 353

5. *System or systems of AVCP (assessment and verification of constancy of performance of the construction product) as set out in Annex V (amended by: OJ L 157, 27.5.2014, p. 76–79):*

System 1 for reaction to fire and system 2+ for other characteristics

6. *European Assessment Document:*

EAD 090001-00-0404 for Prefabricated compressed mineral wool boards with organic and inorganic finish and with specified fastening system.

European Technical Assessment: ETA-24/0910 of 2026-03-11

Technical Assessment Body

ETA-Danmark A/S
Göteborg Plads 1, DK-2150 Nordhavn, Denmark
Tel.: +45 72 24 59 00
Fax.: +45 72 24 59 04
Internet: www.etadanmark.dk

Notified Body:

Materialprüfanstalt für das Bauwesen
Nienburger Strasse 3, D-30167 Hannover, Germany
Notified Body 0764
Tel.: +49 511 762 3104
Fax.: +49 511 762 4001
Internet: www.mpa-bau.de

and issued:

Certificate of Constancy of performance
No. 0764 – CPR – 0388 of 2026-03-11

7. Characteristics of the product

The Rockpanel A2, 8 mm Colours panels are surface treated on one side with water-borne primer- and water-borne coloured paint layers, in a range of colours.

The Rockpanel A2, 8 mm Ply panels are surface treated on one side with water-borne primer layers, in a white colour.

The Rockpanel A2, 8 mm ProtectPlus panels are surface treated on one side with water-borne primer and a water-borne coloured paint, which has been provided with an extra anti-graffiti clear coat on top of the colour paint. The finishes “Woods”, “Stones” and “Chameleon” contain an (additional) design layer on top of the coloured paint. In the event of “Textured” the front side of the board has a slightly textured surface with depths between the product tolerances of +/- 0.5 mm.

The physical properties of ‘Rockpanel A2, 8 mm are indicated below:

Thickness	8 mm
length, max	3050 mm
width, max	1250 mm
density nominal	1170 kg/m ³
bending strength	length and width f ₀₅ ≥ 27 N/mm ²
Modulus of Elasticity	4015 N/mm ²
Thermal conductivity	0.47 W/(m.K)

Clause 8 contains the performances of Rockpanel A2, 8 mm.

8. Declared performance

Table 1 – Euroclass classification of different constructions with Rockpanel A2, 8 mm boards

<i>Essential characteristics</i>		Basic requirements for construction works BR2 – Safety in case of fire		
<i>Harmonised technical specification</i>		ETA-24/0910 issued on 2025-01-28 EN 13501-1		
<i>Performance</i>				
Fixing method	Finish	Set-up	Timber subframe	Metal subframe
Mechanically fixed	Colours, Ply	Non-ventilated. Cavity filled with mineral wool	A2-s1,d0 Closed horizontal joint	
	Colours, Ply, ProtectPlus	Ventilated with EPDM gasket on the battens [a] [c]	A2-s2,d0 Open 8 mm joint	
	Colours, ProtectPlus	Ventilated with EPDM gasket on the battens and windboard in front of the insulation [a] [b]	A2-s1,d0 Open 8 mm joint	
	Colours, ProtectPlus	Ventilated, 28 mm with vertical planks (≥ 100 mm)		A2-s1,d0 Open 10 mm joint
Bonded	Colours, ProtectPlus	Ventilated, with Rockpanel A2, 8 mm strips on the battens [d]	A2-s1,d0 Open 8 mm joint	

[a]: Width of the gasket 15 mm at both sides wider than the batten

[b]: The windboard is specified minimum A2-s1,d0 (according EN 13501-1) and K₁10 (according EN 13501-2) and placed between the subframe and the insulation.

[c]: A breathable membrane (minimum class B-s1,d0 according EN 13501-1) can be added between the subframe and the insulation.

[d]: Width of the strips 15 mm at both sides wider than the batten.

Field of application

The following field of application applies.

Euroclass classification

The classification mentioned in table 1 is valid for the following end use conditions:

Mounting

- Mechanically fixed or adhered as described in table 1, attached to a timber or metal subframe.
- The panels are backed with minimum 50 mm mineral wool insulation with density 30-70 kg/m³ according to EN 13162 with a cavity between the panels and the insulation. See section Insulation below.

- Adhered to a wooden subframe with intermediate Rockpanel strips mechanically fixed.

Substrates:

- Concrete walls, masonry walls and timber framing

Insulation:

- Ventilated constructions: The subframe is backed with minimum 50 mm mineral wool insulation with density 30-70 kg/m³ according to EN 13162 with a cavity of minimum 28 mm for metal subframes and minimal 25 mm for timber subframes between the panels and the insulation.
- Non-ventilated constructions: The panels are backed with minimum 40 mm mineral wool insulation with 30-70 kg/m³ between the battens and minimum 50 mm with density 30-70 kg/m³ behind the battens without an air gap.
- Ventilated constructions and fixing method adhesive: The subframe is backed with minimum 50 mm mineral wool insulation with density 30-70 kg/m³ according to EN 13162 with a cavity of minimum 35 mm between the panels and the insulation.
- Results are also valid for a greater thickness of mineral wool insulation with the same density and the same or better reaction to fire classification.
- The results also apply to panels without insulation, if the substrate chosen according to EN 13238 is made of a panel with Euroclass A1 or A2 (e.g. fibre-cement panels).

Subframe:

- Vertical softwood battens without fire retardant treatment, thickness minimum 25 mm.
- Test results are also valid for the same type of panel with an aluminium or steel frame.
- Test results are also valid for the same type of panel with vertical LVL battens, without fire retardant treatment, thickness minimum 27 mm.

Fixings:

- The results are also valid when using smaller mounting distances.
- Test results are also valid for the same type of panel fixed by rivets made of the same material of screws and vice versa.

Cavity:

- Unfilled or filled with insulation of stone wool with a nominal density 30-70 kg/m³ according to EN 13162.
- The depth of the cavity is minimum 28 mm for a metal subframe, and minimum 25 mm for a timber subframe.
- Test results are also valid for other higher thicknesses of air space between the back of the board and the insulation.

Joints:

- Horizontal joints can be open or closed with an aluminium profile. In the event of a non-ventilated construction an EPDM foam gasket (self-adhering backside) is obliged.
- For metal subframes the vertical joints are without a gasket backing.
- For timber subframes the vertical battens are with an EPDM foam gasket (Celdex EPDM Soft EP-4530), flat EPDM gasket (LineFlex EPDM Geomembrane 0.75 mm or MBE Joint Tape EPDM DF2 – 0,75 mm) or Rockpanel strip backing.
- The result from a test with an open horizontal joint is also valid for the same type of panel used in applications with horizontal joints closed by steel or aluminium profiles.
- Max joint width: 8 mm for a timber subframe and 10 mm for a metal subframe

The classification is valid for the following product parameters:

Thickness: Nominal 8 mm
Density: Nominal 1170 kg/m³

Table 2 – Performance – Water vapour permeability and water permeability

Essential characteristics		BR3 – Hygiene, Health and environment
Property	Declared values	
Water vapour permeability	A2, 8 mm Colours: $s_d < 1.7$ m at 23°C and 85% RH A2, 8 mm Ply: No performance declared A2, 8 mm ProtectPlus $s_d < 3.2$ m at 23°C and 85% RH The designer shall consider the relevant needs for ventilation, heating and insulation to minimise condensation in service.	
Water permeability	Incl. joints for non-ventilated applications: NPD	
		Harmonised technical specification ETA-24/0910 issued on 2025-01-28 EN ISO 12572 test condition B
		ETA-24/0910 issued on 2025-01-28

Table 3 – Performance – Release of dangerous substances

Essential characteristics		BR3 – Hygiene, Health and environment
Property	Product specification	
Dangerous substances	The kit does not contain/release dangerous substances specified in TR 034, dated April 2013*), except Formaldehyde concentration 0.0105 mg/m ³ . Formaldehyde class E1. The used fibres are not potential carcinogenic No biocides are used in the Rockpanel boards No flame retardant is used in the boards No cadmium is used in the boards.	
		Harmonised technical specification ETA-24/0910 issued on 2025-01-28

*) In addition to the specific clauses relating to dangerous substances contained in this European technical Assessment, there may be other requirements applicable to the products falling within its scope (e.g. transposed European legislation and national laws, regulations and administrative provisions). In order to meet the provisions of the Construction Products Regulation, these requirements need also to be complied with, when and where they apply.

**Table 4a – Performance – Design value of the axial load for mechanical fixing 8 mm Rockpanel A2 boards
Subframe: solid wood / metal**

Essential characteristics		BR4 – Safety in use			
Harmonised technical specification		ETA-24/0910 issued on 2025-01-28 EN 14592:2008+A1:2012 (E)			
For service class 2 (see 'Note') and load-duration class 'Instantaneous' [c]. For hole diameters fixings see table 6					
Property	8 mm boards	Span in mm [b]		$X_d = X_k / \gamma_M$ in N Middle / Edge/ Corner	Table in ETA
		a fixing	b board		
Design value of the axial load $X_d = X_k / \gamma_M$	Screw fixing [a] [e] With the use of gaskets	600	600	C18 [d]: 433 / 280 / 148 C24 [d]: 433 / 280 / 148	10-5 [c]
	High Performance nail fixing (35 mm) [e] With the use of gaskets	400	600	C18 [d]: 341 / 271 / 161 C24 [d]: 383 / 271 / 161	10-4 [c]
	Rivet fixing in aluminium [e]	600	600	481 / 321 / 193	10
	Screw fixing in aluminium [e]	600	600	493 / 297 / 152	10-1
	Rivet fixing in steel [e]	600	600	463 / 340 / 221	10-2
	Screw fixing in steel [e]	600	600	416 / 333 / 225	10-3
[a] with $\alpha \geq 30^\circ$: α is the angle between the screw axis and the grain direction [b] see Table 7a and 7b [c] $k_{mod} = 1.10$ in accordance with Table 3.1 – 'Values of k_{mod} 'DS EN 1995-1-1:DK NA:2010; For 'service class' 2 ['ventilated structures protected against precipitation'] and 'load-duration class' 'Instantaneous' [Table 2.2 DS/EN 1995-1-1 DK NA:2010-05]		[d] Strength class BS EN 338 [e] for specifications fixings see table 9a to 9e Note (according to DS EN 1995-1-1:2004+A1:2014 §2.3.1.3 (3)P): Service class 2 "ventilated structures protected against precipitation, e.g. ventilated roof structures". EN 1995-1-1: In service class 2 the average moisture content in most softwoods will not exceed 20%			

Table 4b – Performance – Design value of the axial load for mechanical fixing 8 mm Rockpanel A2 boards
Subframe: solid wood / metal

Essential characteristics		BR4 – Safety in use			
Harmonised technical specification		ETA-24/0910 issued on 2025-01-28 EN 14592:2008+A1:2012 (E)			
For service class 3 (see 'Note') and load-duration class ' Instantaneous ' [c]. For hole diameters fixings see table 6					
Property	8 mm boards	Span in mm [b]		$X_d = X_k / \gamma_M$ in N Middle / Edge/ Corner	Table in ETA
		a fixing	b board		
Design value of the axial load $X_d = X_k / \gamma_M$	Screw fixing [a] [e] With the use of gaskets	600	600	C18 [d]: 433 / 280 / 148 C24 [d]: 433 / 280 / 148	10-5 [c]
	High Performance nail fixing (35 mm) [e] With the use of gaskets	400	600	C18 [d]: 279 / 271 / 161 C24 [d]: 333 / 271 / 161	10-4 [c]
	Rivet fixing in aluminium [e]	600	600	481 / 321 / 193	10
	Screw fixing in aluminium [e]	600	600	493 / 297 / 152	10-1
	Rivet fixing in steel [e]	600	600	463 / 340 / 221	10-2
	Screw fixing in steel [e]	600	600	416 / 333 / 225	10-3
[a] with $\alpha \geq 30^\circ$: α is the angle between the screw axis and the grain direction [b] see Table 7a and 7b [c] $k_{mod} = 0.90$ in accordance with Table 3.1 – 'Values of k_{mod} ' DS EN 1995-1-1 DK NA:2010-05; For 'service class' 3 ["External uses fully exposed"] and 'load-duration class ' Instantaneous ' [Table 2.2 DS EN 1995-1-1 DK NA:2010-05]		[d] Strength class BS EN 338 [e] for specifications fixings see table 9a to 9e Note (according to DS EN 1995-1-1 DK NA:2010-05 §2.3.1.3 (3)P): Service class 3 is characterised by climatic conditions leading to higher moisture contents than in service class 2 (compare 'Note' in Table 4a).			

Table 4c – Performance – Design value of the axial load for mechanical fixing 8 mm Rockpanel A2 boards
Subframe: solid wood / metal

Essential characteristics		BR4 – Safety in use			
Harmonised technical specification		ETA-24/0910 issued on 2025-01-28 EN 14592:2008+A1:2012 (E)			
For service class 2 (see 'Note') and load-duration class ' Permanent ' [c]. For hole diameters fixings see table 6					
Property	8 mm boards	Span in mm [b]		$X_d = X_k / \gamma_M$ in N Middle / Edge/ Corner	Table in ETA
		a fixing	b board		
Design value of the axial load $X_d = X_k / \gamma_M$	Screw fixing [a] [e] With the use of gaskets	600	600	C18 [d]: 396 / 280 / 148 C24 [d]: 425 / 280 / 148	10-5 [c]
	High Performance nail fixing (35 mm) [e] With the use of gaskets	400	600	C18 [d]: 186 / 186 / 161 C24 [d]: 222 / 222 / 161	10-4 [c]
	Rivet fixing in aluminium [e]	600	600	481 / 321 / 193	10
	Screw fixing in aluminium [e]	600	600	493 / 297 / 152	10-1
	Rivet fixing in steel [e]	600	600	463 / 340 / 221	10-2
	Screw fixing in steel [e]	600	600	416 / 333 / 225	10-3
[a] with $\alpha \geq 30^\circ$: α is the angle between the screw axis and the grain direction [b] see Table 7a and 7b [c] $k_{mod} = 0.60$ in accordance with Table 3.1 – 'Values of k_{mod} ' DS EN 1995-1-1:DK NA:2010; For 'service class' 2 ["ventilated structures protected against precipitation"] and 'load-duration class ' Permanent ' [Table 2.2 DS / EN 1995-1-1 DK NA:2010-05]		[d] Strength class BS EN 338 [e] for specifications fixings see table 9a to 9e Note (according to DS EN 1995-1-1:2004+A1:2014 §2.3.1.3 (3)P): Service class 2 "ventilated structures protected against precipitation, e.g. ventilated roof structures". EN 1995-1-1: In service class 2 the average moisture content in most softwoods will not exceed 20%			

Table 5 – Performance – Design value of the axial load for mechanical fixing A2 8 mm strips for bonding purposes.
Subframe: solid wood

Essential characteristics		BR4 – Safety in use					
Harmonised technical specification		ETA-24/0910 issued on 2025-01-28 EN 14592:2008+A1:2012 (E)					
For service class 2 (see 'Note') and load-duration class 'Instantaneous' [c]. For hole diameters fixings see table 6							
Property	8 mm strips [b] in combination with	Span in mm			$X_d = X_k / \gamma_M$ in N		Table in ETA
		a_2	a fixing	b adhesive ridge	SE: start/end of the strip	SM: middle of the strip	
Design value of the axial load $X_d = X_k / \gamma_M$ [c]	Screw fixing and intermediate strips [a] [e]	≥ 50	400	600	C18 [d]: 203 C24 [d]: 203	C18 [d]: 280 C24 [d]: 280	10-8
	Screw fixing and end strips or joint strips [a] [e]	≥ 50	400	600	C18 [d]: 203 C24 [d]: 203	C18 [d]: 280 C24 [d]: 280	10-7
	HP nail fixing and intermediate strips [e]	≥ 50	300	600	C18 [d]: 164 C24 [d]: 164	C18 [d]: 271 C24 [d]: 271	10-10
	HP nail fixing and end joint or joint strip [b] [e]	≥ 50	300	600	C18 [d]: 198 C24 [d]: 198	C18 [d]: 271 C24 [d]: 271	10-9
Strips for a wooden subframe:		Located on vertical joints			Located on end or between joints		
<p>[a] with $\alpha \geq 30^\circ$: α is the angle between the screw axis and the grain direction</p> <p>[b] fixed points in the middle of the length of the strip</p> <p>[c] $k_{mod} = 1.10$ Table 3.1 – 'Values of k_{mod} 'DK EN 1995-1-1 DK NA 2010. For 'service class 2' ['ventilated structures protected against precipitation'] External and Load-duration class 'Instantaneous' [Table 2.2 DS EN 1995-1-1 DK NA:2010-05]</p> <p>[d] Strength class BS EN 338</p> <p>[e] for specifications fixings see table 9d and 9e</p> <p>Note (according to DS EN 1995-1-1 NA: 2010-05 §2.3.1.3 (3)P): Service class 2- "ventilated structures protected against precipitation, e.g. ventilated roof structures". EN 1995-1-1: In service class 2 the average moisture content in most softwoods will not exceed 20 %.</p>							

Table 6 – Performance mechanical fixings – Hole diameters for A2 boards

Essential characteristics		BR4 – Safety in use			
Harmonised technical specification		ETA-24/0910 issued on 2025-01-28			
Fixing type [a]	Fixed hole	Moving hole	Slotted hole	Board dimension considered	
Screw for timber	3.2	6.0	3.4 * 6.0	1200 * 3050	
High Performance Nail	2.5	3.8	2.8 * 4.0	1200 * 2420	
Rivet	5.1	8.0	5.1 * 8.0	1200 * 3050	
Screw for aluminium [b]	5.8	10.0	n.a.	1200 * 3050	
Screw for steel	4.3	8.0	4.3 * 8.0	1200 * 3050	

[a] For specifications fixings see Table 9a to 9e.

[b] The self-drilling screw for aluminium should always be fastened with 2 fixed points on the same horizontal level, max width 600 mm.

Table 7a – Performance fixings according to table 4, 5 and 6 with the required edge distances, maximum distances and horizontal installation of boards.

Essential characteristics	BR4 – Safety in use				
Harmonised technical specification	ETA-24/0910 issued on 2025-01-28 Table 7 and fig. 2				
	FP/SP [b]	'Fixed hole' FP and 'slotted holes' SP (according to table 6) in the middle of the vertical part of the board All the other fixings points are 'moving points'			
	l_m	Length max 3050 mm			
	l_{mv}	'moving length' \leq 1510 mm			
	l_b	Length of the board			
	b_2	Max. 400 mm; b_2 in the central area of the board length l_b			
	FPM [b]	Creating a fixed point by the use of a sleeve FPM 			
	Location of the fastener: M: Middle of the board E: Edge of the board C: Corner of the board				
	Fixing type	b_{max}	a_{max}	a_1	a_2
	Rivet [a]	600	600	≥ 20	≥ 50
	Screw for metal	600	600	≥ 20	≥ 50
Screw for timber	600	600	≥ 15	≥ 50	
HP Nail	600	400	≥ 15	≥ 50	
Adhesive	600	Continuously applied triangular adhesive ridge of 9 mm			
Use of sleeves for Rivet fixing		Drill hole according to Table 6		Sleeve	
Subframe Aluminium	FPM – Sleeve [a] [b]	8 mm		$\varnothing 8 \times 7,5$ – drill hole $\varnothing 5.1$	
	FP – 'Fixed point' FP (according to Table 6) in central area of the vertical edge of the board.				

[a]: For correct fixing (SP, FP and SPM) a riveting tool with rivet spacer must be used (e.g. 0.3 mm).

[b]: Subframe aluminium

Table 7b – Performance fixings according to table 4, 5 and 6 with the required edge distances, maximum distances and vertical installation of boards.

<i>Essential characteristics</i>		BR4 – Safety in use	
<i>Harmonised technical specification</i>		ETA-24/0910 issued on 2025-01-28 Table 7 and fig. 2	
		FP/SP [b]	'Fixed points' FP and 'slotted points' SP (according to Table 6) in the middle of the vertical part of the board
		FPM [b]	Fixed point realized by a sleeve FPM
		SPM [b]	Slotted hole realized by a side sleeve
All the other fixing points are 'moving' points.			
		l_b	Length of the board
		l_{b2}	Ca $l_b / 2$
		b_3	max. 400 mm
		b_4	max. 600 mm
		<i>Drill hole according to Table 6</i>	<i>Sleeve</i>
Subframe	FPM – Sleeve [a] [b]	8 mm	Ø8 x 7,5 – drill hole Ø5.1
Aluminium	SPM – Side sleeve [a][b]	8 mm	Ø8 x 7,5 – drill hole Ø5.1 x 6.2

[a]: For correct fixing (SP, FP and SPM) a riveting tool with rivet spacer must be used (e.g. 0.3 mm).

[b]: Subframe aluminium

Table 8 – Performance shear strength mechanical fixings

<i>Essential characteristics</i>		BR4 – Safety in use	
<i>Harmonised technical specification</i>		ETA-24/0910 issued on 2025-01-28	
		<i>Fixing</i>	<i>Failure load</i>
Characteristic shear strength mechanical fixings Average values		Rivet for aluminium	2718 N
		Screw for aluminium	2347 N
		Rivet for steel	2913 N
		Screw for steel	2293 N
		Torx Screw for timber	2254 N
		High performance nail	1423 N
			<i>Deformation</i>
			3.3 mm
			4.0 mm
			2.9 mm
			2.2 mm
			7.1 mm
			7.5 mm

Table 9a – Specifications mechanical fixings – Rivet aluminium or stainless steel [e]

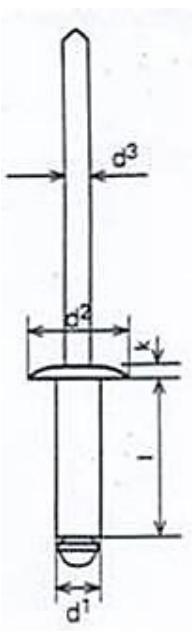
		SFS Aluminium [d]	SFS Stainless steel A4 [a] [b]	MBE Aluminium [d]	MBE Stainless steel [a] [b]
	Code	AP14-50180-S	SSO-D15-50180	FN-AI5-5x18 K14	FN-A4-5x18 K15
Body	Aluminium EN AW-5019 (AlMg5) in accordance with EN 755-2	Stainless steel material number 1.4578 in accordance with EN 10088	Aluminium EN AW-5019 (AlMg5) in accordance with EN 755-2	Stainless steel material number 1.4578 in accordance with EN 10088	
Mandrel	Stainless steel material number 1.4541 in accordance with EN 10088	Stainless steel material number 1.4541 in accordance with EN 10088	Stainless steel material number 1.4541 in accordance with EN 10088	Stainless steel material number 1.4541 in accordance with EN 10088	
Pull-out strength	$F_{u,5} = 1882 \text{ N}$	$F_{u,5} = 1339 \text{ N}$	$F_{u,5} = 1882 \text{ N}$	$F_{u,5} = 1339 \text{ N}$	
d ¹	5	5	5	5	
d ²	14	15	14	15	
d ³	2.7	3.25	2.7	3.25	
L	18	18	18	18	
k	1.5	1.5	1.5	1.5	
Profile	Aluminium t ≥ 1.5 mm	Steel t ≥ 1.0 mm	Aluminium t ≥ 1.5 mm	Steel t ≥ 1.0 mm	

[a]: The minimum thickness of the vertical steel profiles is 1.0 mm. The steel quality is S280GD +Z EN 10346 number 1.0250 (or equivalent for cold forming).

[b]: The minimum thickness of the vertical steel profiles is 1.5 mm. The steel quality is EN 10025-2:2004 S235JR number 1.0038. For minimum coating thickness see [c].

[c]: The minimum coating thickness (Z or ZA) is determined by the corrosion rate (amount of corrosion loss in thickness per year) which depends on the specific outdoor atmospheric environment. The International Zinc association can be consulted for more information.

The coating designation (classification which determines the coating mass) shall be agreed between the contractor and the building owner. Alternatively a hot dip galvanized coating according to EN ISO 1461 can be used.

[d]: The aluminium is minimum AW-6060 according EN 755-2. The $R_m/R_{p0,2}$ value is ≥ 170/140 for profile T6 and ≥ 195/150 for profile T66.

[e]: For correct fixing a riveting tool with rivet spacer must be used (e.g. 0.3 mm)

Table 9b – Specifications mechanical fixings – Self-drilling screw for aluminium

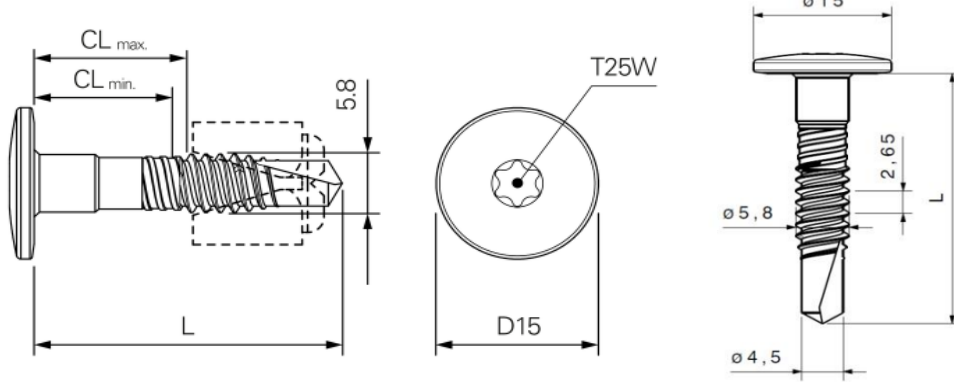
Stainless steel A4 in accordance with EN ISO 3506 - code: SDA4-D15-CS10/8-5.8x29-A4	
Length: 29 mm → clamping length: 9.8 – 11.0 mm [a]	

[a]: The minimum thickness of the aluminium profiles is 1.8 mm.

Table 9c – Specifications mechanical fixings – self-drilling screw for steel sub-constructions

Self-drilling screw for steel sub-constructions – code JT6-FR-3-5,5 x L Screw length 25 mm: Clamping length 9 mm Screw length 35 mm: Clamping length 19 mm	

Table 9d – Specifications mechanical fixings – fasteners for timber sub-constructions.

Ring-shank nail – High Performance version 2.7/3.1 x 35 mm Stainless steel in accordance with EN 10088 - Material number 1.4401 or 1.4578 Definitions in accordance with EN 14592:2008+A1:2012	
$d_n = 2,7 \pm 0,1$ $d_1 = 3,1 \pm 0,1$ $l_n = 35 \pm 1,0$ $l_2 = 28 \pm 1,0$ $l_g = 25 \pm 1,0$ $l_p = 3 \pm 0,5$ $d_h = 6 \pm 0,2$ $h_t = 0,9 \pm 0,1$	

Table 9e – Specifications mechanical fixings – fasteners for timber sub-constructions.

Torx screws 4.5 x 35 mm Stainless steel in accordance with EN 10088 - Material number 1.4401 or 1.4578 Definitions in accordance with EN 14592:2008+A1:2012	
$d = 4.3 - 4.6$ $d_s = 3.3 - 3.4$ $d_h = 9.6 - 0.4$ $l = 35 - 1.25$ $l_g = 26.25 - 28.5$	

Table 10 – Performance Bostik S970 Paneltack S adhesive and Foam tape – Initial tensile strength

<i>Essential characteristics</i>	BR4 – Safety in use			
<i>Harmonised technical specification</i>	ETA-24/0910 issued on 2025-01-28			
	<i>Conditions</i>	<i>Contact surfaces – Rear of the board onto</i>	<i>Characteristic N/mm¹</i>	<i>Design N/mm¹</i>
Bostik S970 Paneltack S adhesive [a] [b]	-40°C, -20°C, +23°C and +80°C	Strips with ProtectPlus	$X_k = 9.45$	$X_d = 2.36$
		Strips with Colours	$X_k = 10.75$	$X_d = 2.69$
		Aluminium	$X_k = 7.80$	$X_d = 1.95$
Foam tape [a]	+23°C	Strips with ProtectPlus	$X_k = X_d = 2.03$	
		Strips with Colours	$X_k = X_d = 2.14$	
		Aluminium	$X_k = X_d = 2.93$	

[a]: For the partial load $\gamma_F = 1.5$ shall be taken

[b]: Partial material factor for material property $\gamma_M = 4$ (tensile caused by wind load)

Table 11 – Performance Bostik S970 Paneltack S adhesive and Foam tape – Initial shear strength

<i>Essential characteristics</i>	BR4 – Safety in use			
<i>Harmonised technical specification</i>	ETA-24/0910 issued on 2025-01-28			
	<i>Conditions</i>	<i>Contact surfaces – Rear of the board onto</i>	<i>Characteristic N/mm¹</i>	<i>Design N/mm¹</i>
Bostik S970 Paneltack S adhesive [a] [b]	-40°C, -20°C, +23°C and +80°C	Strips with ProtectPlus	$X_k = 2.49$	$X_d = 0.062$
		Strips with Colours	$X_k = 2.49$	$X_d = 0.062$
		Aluminium	$X_k = 1.99$	$X_d = 0.050$
Foam tape [a] [c]	+23°C	Strips with ProtectPlus	$X_k = X_d = 1.17$	
		Strips with Colours	$X_k = X_d = 1.17$	
		Aluminium	$X_k = X_d = 0.75$	

[a]: For the partial load $\gamma_F = 1.5$ shall be taken

[b]: Partial material factor for material property $\gamma_M = 40$ (shear caused by permanent load)

[c]: Partial material factor for material property $\gamma_M = 1$ (shear caused by temporary load)

Table 12 – Performance Bostik S970 Paneltack S adhesive – Shear: deformation declared

<i>Essential characteristics</i>	BR4 – Safety in use		
<i>Harmonised technical specification</i>	ETA-24/0910 issued on 2025-01-28		
	<i>Conditions</i>	<i>Contact surfaces – Rear of the board onto</i>	<i>Deformation [%]</i>
Bostik S970 Paneltack S adhesive	-40°C, -20°C, +23°C and +80°C	Strips with ProtectPlus and Colours	348 – 871 %
		Aluminium	331 – 718 %

Table 13 – Performance Bostik S970 Paneltack S adhesive – Characteristic tensile strength

<i>Essential characteristics</i>	Aspects of durability and serviceability		
<i>Harmonised technical specification</i>	ETA-24/0910 issued on 2025-01-28		
	<i>Contact surfaces – Rear of the board onto</i>	<i>Performance N/mm¹</i>	
		<i>21 days</i>	<i>42 days</i>
Immersion in water without UV	Strips with ProtectPlus and Colours	$X_k = 8.10$	$X_k = 7.42$
	Aluminium	$X_k = 6.02$	$X_k = 5.82$

Table 14 – Performance Bostik S970 Paneltack S adhesive – Characteristic tensile strength

<i>Essential characteristics</i>	Aspects of durability and serviceability	
<i>Harmonised technical specification</i>	ETA-24/0910 issued on 2025-01-28	
	<i>Contact surfaces – Rear of the board onto</i>	<i>Performance N/mm¹</i>
Humidity and NaCl	Aluminium	$X_k = 8.03$
Humidity and SO ₂	Aluminium	$X_k = 8.68$

Table 15 – Performance Impact resistance

<i>Essential characteristics</i>	BR4 – Safety in use		
<i>Harmonised technical specification</i>	ETA-24/0910 issued on 2025-01-28		
	<i>Sub-construction</i>	<i>Category</i>	
Panels without a horizontal joint	Timber	III	
	Metal	III	
Panels with a horizontal joint ready accessible and vulnerable to impacts	Timber	III	
	Metal	III	

Table 16 – Performance dimensional stability

<i>Essential characteristics</i>	BR4 – Safety in use		
<i>Harmonised technical specification</i>	ETA-24/0910 issued on 2025-01-28		
	<i>Length</i>	<i>Width</i>	
Cumulative dimensional change [a]	0.072 %	0.072 %	

[a]: As a consequence the minimum joint width shall be 3 mm, preferably 5 mm.

Table 17 – Resistance to hygro-thermal cycles and Xenon Arc exposure

<i>Essential characteristics</i>	Aspects of durability and serviceability		
<i>Harmonised technical specification</i>	ETA-24/0910 issued on 2025-01-28		
		<i>Performance</i>	
Resistance to Hygrothermal cycles		Pass	
Resistance to Xenon Arc exposure <i>EOTA TR010 climate class S (Technical Report 010)</i> 5000 hours artificial weathering	Finish ‘Colours’	ISO 105 A02: 3-4 or better	
	Finish ‘Ply	No performance declared	
	Finish ‘ProtectPlus’	ISO 105 A02: 4 or better	

9. The performance of the product identified above is in conformity with the set of declared performances. This declaration of performance is issued, in accordance with Regulation (EU) No 305/2011, under the sole responsibility of the manufacturer identified above.

Signed for and on behalf
of the manufacturer by:

ROCKWOOL B.V.
E. de Wolf
Managing Director

At: Roermond,
The Netherlands

on: 11-05-2026

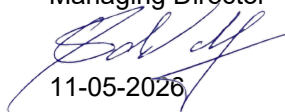

DOP in accordance with Commission Delegated Regulation (EU) No 574/2014 of 21 February 2014 amending Annex III to Regulation (EU) No 305/2011 of the European Parliament and of the Council on the model to be used for drawing up a declaration of performance on construction products, <http://eur-lex.europa.eu/legal-content/EN/TXT/?uri=celex%3A32014R0574>, OJ L 159, 28.5.2014, p. 41–46