

Rockfon® Medical™ Standard

Features & Benefits

- Designed to meet essential cleaning and hygiene requirements for general healthcare areas
- Optimal sound absorption with NRC of 0.90 and system CAC up to 52
- Meets FGI guidelines for healthcare facilities
- Has a low particle emission achieving ISO Class 5 per ISO14644-1 using Chicago Metallic® BarrierGrid® for better air cleanliness
- Tested per ASTM D4828 for washability and ASTM D2486 for scrub resistance
- Stone wool is inherently mold and mildew resistant without added antimicrobials
- UL GREENGUARD Gold certified for low chemical emissions
- Compliant with the Build America, Buy America Act (BABAA)

Applications

- Nurses' Station
- Waiting Area
- Reception
- Office
- Corridor

Tile Performance



System Performance



See Table 2

GWP AS LOW AS



2.04 kg CO₂-eq/1m²
0.190 kg CO₂ eq/ft²

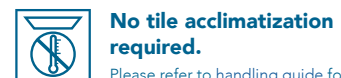
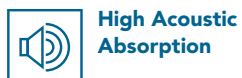

Please refer to [handling guide](#) for details.

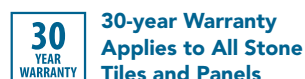

Rockfon® Medical™ Standard



Scan to explore Rockfon® Medical™ Standard Sustainability Certifications and Documentation

High Performance Factors

Base Material	Stone Wool
Surface	Lightly Textured
Fire Performance	Class A Tested to US Standard ASTM E84: Flame Spread Index: 0 Smoke Developed Index: 0 Canadian Standard CAN/ULC S102: Flame Spread Rating: 15 Smoke Developed Classification: 5
Warranty	30-Year Tile Warranty

Mold & Mildew Resistance	Inherently Resistant (applies to stone wool substrate and tile surfaces) Tested to ASTM D3273: 10 (Scale of 0 to 10, 10 being highest performing) Tested to ASTM C1338: Pass (Pass or Fail, Stone Wool Tiles Pass)
Sag Resistance	Won't Sag or Warp Even in 100% Relative Humidity Tested to ASTM C367
Low VOC	UL GREENGUARD Gold Certified



Table 1

Medical Standard Panels

Edge Designation	Item Number	Modular Size (nominal)	NRC	AC	Fire Class	Mold & Mildew Resistance	Light Reflectance	Cleanroom Class	Embodied Carbon		Sag Resistance (relative humidity)	Low VOC	Recyclable	Packaging Information	
									Per 1m ² (kg CO ₂ - eq)	Per 1ft ² (kg CO ₂ - eq)				lbs/sqft	sqft/carton
 SQ Square Lay-In	33200	2' x 2' x 5/8"	0.90	170	A	✓	0.86	ISO 5	2.04	0.190	up to 100%	✓	✓	0.38	112
	33201	2' x 4' x 5/8"	0.90	170	A	✓	0.86	ISO 5	2.04	0.190	up to 100%	✓	✓	0.38	112
 SLN Square Tegular Narrow	33225	2' x 2' x 5/8"	0.90	170	A	✓	0.86	ISO 5	2.43	0.226	up to 100%	✓	✓	0.47	56
	33226	2' x 4' x 5/8"	0.90	170	A	✓	0.86	ISO 5	2.43	0.226	up to 100%	✓	✓	0.47	112
 SL Square Tegular	33250	2' x 2' x 5/8"	0.90	170	A	✓	0.86	ISO 5	2.43	0.226	up to 100%	✓	✓	0.47	56
	33251	2' x 4' x 5/8"	0.90	170	A	✓	0.86	ISO 5	2.43	0.226	up to 100%	✓	✓	0.47	112

Rockfon® Medical™ Standard

Table 2

System Performance with Medical Standard Panels - CAC 40-52¹

Product	NRC	Plenum Barrier Board as Ceiling Panel Backer (Horizontal Application) ²	Plenum Barrier Board as Partition Extension (Vertical Application)		Plenum Barrier Board
			Single-Layer	Double-Layer	
Medical Standard 5/8"	0.90	44	40	52	<p>Rockfon® Plenum Barrier Board is a stone wool noise blocking panel, which is installed over partitions inside ceiling plenums, on top of ceiling panels or under partitions in raised-floor plenums to increase sound insulation and privacy between rooms.</p> <p>Actual board size 2' x 4' x 1-1/2" (SKU#7900) with fiber reinforce foil facing on one side. Click to access Rockfon Plenum Board datasheet.</p>



¹Use the system in Table 2 that provides a CAC rating at least equal to the STC rating of the partition between the rooms.

²Assumes plenum barrier applied to full ceilings both sides of walls. Contact Rockfon for performance of 1-side and not the other.



[Click Here or Scan QR Code](#)
to see more information in The Ceilings Book™.

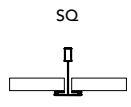





Product Compatibility

15/16" Suspension Systems		9/16" Suspension Systems	
200, 1200 and Fire Rated Systems	Chicago Metallic® BarrierGrid®*	4000, 4500, 4600 and Fire Rated Systems	
<p>SQ SL</p>  <p>Square Lay-in Square Tegular</p>	<p>SQ</p>  <p>Square Lay-in</p>	<p>SQ - Square Lay-in SLN - Square Tegular Narrow</p>  <p>4000 - Tempra 4000 - Tempra 4500 - Ultraline 1/4" Reveal 4600 - Ultraline 1/8" Reveal</p>	

*Rockfon® Medical™ Standard achieves ISO Class 5 using Chicago Metallic® BarrierGrid®

Rockfon® Medical™ Standard

Accessories

	Detail	Rockfon Part Number	Product Number	Product Description	Packaging	
					Pcs/ Ctn	Lbs/ Ctn
General Clips*		250348	935.00	Universal Hold Down Clip	1000	16
		252923	425.01	Hold Down Clip for 5/8" Board 250/1250 Systems	200	2
		250343	820.00	Hold Down Clip for 5/8" Board 250/1250 Systems	1000	7
		237949	490.00	Hold Down Clip for 0" - 3/4" Panels (Black)	100	2
		237952	491.00	Hold Down Clip for 3/4" - 1-1/4" Panels (Blue)	150	2
		250324	426.01	Butterfly Retention Clip for 0" - 1" Panels	200	15
Tile Paint		307988	RFN941	Edge Paint for Field Cut Panels White – 1/2" pint. Brush included.	Can	1
		307989	RFN941Q	Edge Paint for Field Cut Panels White – 32 oz	Can	1

*Clips should be chosen as per tile thickness

Scan for Full
Accessories Guide



Rockfon® Medical™ Standard Properties

Material

Stone wool (Mineral Wool) ceiling tiles with factory applied water-based paint on glass scrim surface.



ASTM E1264 Classification

ASTM E1264 (2022): Type IV, Form 3, Pattern E
ASTM E1264 (2023): Type A, Form A2.3, Pattern E



Acoustic Performance

Rockfon® Medical Standard™ ceiling panels are tested for Noise Reduction Coefficient (NRC) and Ceiling Attenuation Class (CAC) according to the following ASTM standards:

✓ NRC – Tested to ASTM C423

✓ CAC – Tested to ASTM E1414



Fire Performance

Rockfon® Medical Standard™ tiles are tested for Surface Burning Characteristics to UL 723 (ASTM E84) for the US and CAN/ULC-S102 for Canada, and achieve:

Tested to US Standard Flame Spread Index: 0
UL 723 (ASTM E84): Smoke Developed Index: 5

Canadian Standard Flame Spread Rating: 15
CAN/ULC S102: Smoke Developed Classification: 5



Mold and Mildew Resistance

Stone wool is inherently resistant to mold and mildew without added antimicrobials. Both, tile surface and substrate, are tested to:

✓ ASTM D3273 (Standard Test Method for Resistance to Growth of Mold on the Surface of Interior Coatings)

✓ ASTM C1338 (Standard Test Method for Determining Fungi Growth Resistance of Insulation Materials and Facings)



Humidity Resistance

Stone wool ceiling tiles are inherently humidity resistant and are tested to ASTM C367 (Standard Test Methods for Strength Properties of Prefabricated Architectural Acoustical Tile or Lay-In Ceiling Panels) and won't sag or warp even in 100% relative humidity



Clean Room

ISO Class 5 when used with Chicago Metallic® BarrierGrid®



Cleaning

✓ Vacuum

✓ Damp cloth

✓ Rockfon® Medical Standard™ tiles are able to be washed through 100 cycles of the standard washability tester and cleaner prescribed in ASTM D4828.

✓ Rockfon® Medical Standard™ tiles can withstand up to 100 scrub cycles using the prescribed scrubber and force per ASTM D2486



Thermal Resistance

R 2.17 hr.ft².°F/Btu for 5/8 inch (I-P)
R 0.38 m².K/W for 15.9 mm (SI)



Warranty

30-Year Limited Product Warranty.
See rockfon.com

Sustainability



Transparency

✓ Environmental Product Declaration (Product-Specific, Type III)

✓ Health Product Declaration

Applicable to all edge types



Low-Emitting Materials

UL GREENGUARD Gold certified for low VOC (chemical) emissions and meet the California Department of Public Health (CDPH) Standard Method v1.2-2017 for offices and classroom environments



Embodied Carbon

Global Warming Potential (GWP) kg of CO₂-eq (per functional unit) from stages A1 - A3 for SQ Edge: 2.04 kg CO₂-eq (per 1m²) / 0.190 kg CO₂-eq (per 1f²)

For all other edge types, refer to p. 2



Rockcycle - Closed Loop Recycle Program

All stone wool ceiling tiles are eligible for the Rockcycle program. Please contact rockcycle@rockfon.com for more information



Discover Rockfon® Medical Standard™

on Ecomedes and see how it aligns with the Common Materials Framework (CMF)

Find us on

MasterSpec[®]
Powered by Deltek Specpoint[®]

BIM/Revit objects available at:
rockfon.com/products/rockfon-medical-standard/